

Molten Carbonate Fuel Cell Application and Business Status of POSCO Power

Jung-Tae Hwang

Fuel cell R&D center, POSCO Power, South Korea, 794-941

Abstract

Energy is the primary resource to sustain the human society, and it is a very important fundamental basis for the social and economical development. Fuel cell is one of the most efficient devices to generate electricity from either fossil or renewable fuels: it is a clean and efficient energy supply system. POSCO Power and Fuel Cell Energy have commercialized the line-up of 350, 1400 and 2800 kW products and installed them as much as 22.5MW up to now in Korea. Our recent focus has been given to the establishment of a stack manufacturing facility in Korea, which means a completion of fuel cell technology and business localization from manufacturing to service/maintenance. Furthermore, POSCO Power is continuously developing various application products for the purpose of the fuel cell business market diversification such as “uninterrupted power generator”, “ship service fuel cell” as well as “fuel cell/turbine hybrid system” for extending the system efficiency.

Key words: molten carbonate fuel cell, fuel cell/turbine hybrid system

Introduction

Energy is the primary resource to sustain the human society, and it is a very important fundamental basis for the social and economical development. However, the severe usages of fossil fuel have brought to cause the challenges such as environmental pollutions, and global warming, even ecosystem deterioration. Moreover, the explosive economic development rate of developing countries has accelerated the huge amount of fossil fuel consumption so that the resources of fossil fuel caused to exhaust. In recent years, increasing attention has been given to a renewable and clean energy sources and devices.

A fuel cell is a very unique and promising technology which can meet the requirements described above. It is an electrochemical device that converts chemical energy directly into electrical energy. The structure of fuel

cells is similar to that of traditional batteries, where an anode, cathode, and electrolyte exist. Differently from a battery, the electric power by electrochemical reactions is continuously produced as long as fuel is supplied. Since it can use both fossil energy and hydrogen as fuel, it can absorb the social and economic shock of the transition of energy paradigm. Since its scale varies from sub-MW to MW, various types and applications become available.

Among the various types of fuel cells, molten carbonate fuel cell (MCFC) is considered to have the strong competitiveness in current market of the stationary application. Also, it has strong potential to further increase the system efficiency since the hybrid or integration with turbine system is suitable due to its high temperature operation. In MCFC, a molten carbonate salt mixture is used as its electrolyte. The composition of the electrolyte varies, but usually consists of lithium carbonate and potassium carbonate. At the operating

temperature of about 1200°F (650°C), the salt mixture is liquid and a good ionic conductor. The electrolyte is suspended in a porous, insulating and chemically inert ceramic matrix.

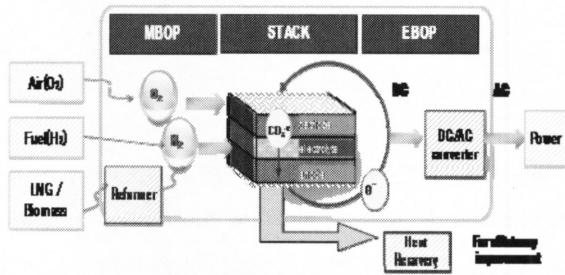
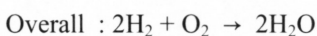
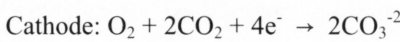
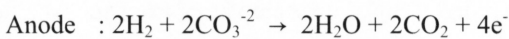

Fig.1. Schematic of the fuel cell system

Heated to 650°C, the salts melt into a molten state that can conduct ions (CO₃²⁻), between cathode and anode. At the anode, hydrogen reacts with the ions to produce water, carbon dioxide, and electrons. The electrons travel through an external circuit to provide electrical power before they return to the cathode. At the cathode, oxygen from the air and carbon dioxide recycled from the anode react with electrons to form CO₃²⁻ ions that replenish the electrolyte and transfer current through the fuel cell. The main electrochemical reactions occurring at the anode and cathode sides are as follows:



As seen above, MCFC generator is installed with a “CO₂ transfer device” due to the requirement of CO₂ supply at the cathode side. Hydrogen is usually provided as a form of methane (CH₄) in NG. The methane goes through a gas cleaner and humidifier where sulfur and other higher hydrocarbons are removed. After the cleaning process, the gas is mixed with water and heated to about 400°C before it is injected into the cells. Inside the cell, with the help of a catalyst, the following

reaction takes place:

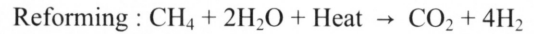

As seen in Fig. 1, MCFC system is comprised by three modules: Stack, MBOP, and EBOP. In order to obtain the sufficient voltage and current, cells are connected serially. This multi-story structure of cells is called a Stack. The module supplied with hydrogen and oxygen to the stack is called MBOP (Mechanical Balance of Plant). EBOP (Electrical Balance of Plant) converts DC generated from the stack to AC and supply it to customers. These three modules comprise the fuel cell system.

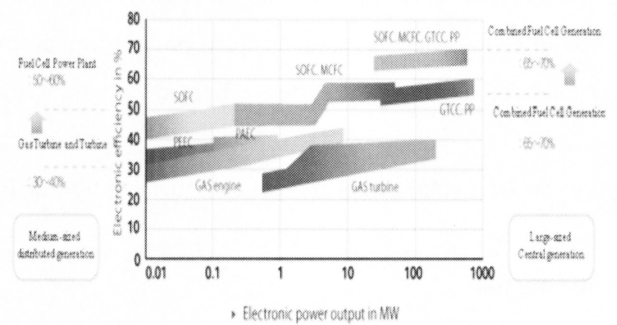

Fig.2. Efficiency index of MCFC

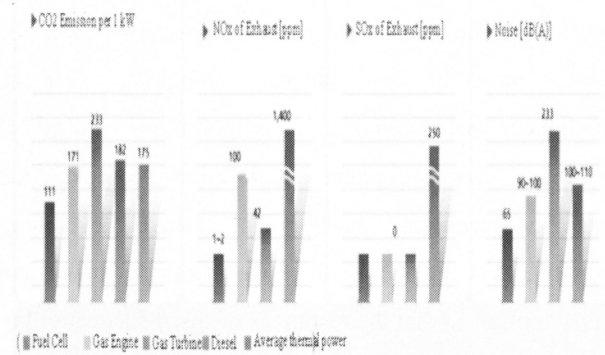

Fig.3. Eco-friendly index of MCFC

Within alternative fuel cell system, MCFC is given to a considerable technology for the energy generation in stationary application such as distributed generation, due to their several advantages as follows.

- (i) More efficient than competing technologies: its power generating efficiency reaches 40~ 60% and this can dramatically reduce energy costs. When heat is used, energy efficiency can reach up to 80%.
- (ii) Low emission and noise free: it can even be installed in residential areas because it causes neither air pollutions nor noises.
- (iii) Less expensive than grid to operate: system can be modulated and decentralized so that it will be less expensive and suitable to construct a grid with other generator.
- (iv) Available to use it as base load (uninterrupted based load power supply): it can effectively respond to power failures arising out of disasters through 24 hour electric supply because it doesn't get affected by weather.
- (v) Multi-fuel usages: fuel supply is much easier because various gases can be used such as natural gas, methane gas and bio gas (gas generated from sewage disposal plants and landfills)
- (vi) Unmanned operation (i.e. customer-controlled): personnel management is easier since it can be operated through internet

Business status of POSCO Power

The recent focus of POSCO Power has been given to the establishment of a stack manufacturing facility in Korea, which means a completion of fuel cell technology and business localization from service, maintenance to the manufacturing.

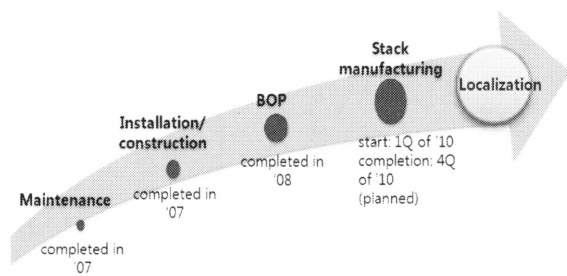

Fig.4. Fuel cell business strategic of POSCO Power

As seen in Fig. 4, POSCO Power has been already localized the MBOP area by completing of construction of the world's largest BOP manufacturing facility in 2008. By launching to establish the stack manufacturing facility, POSCO Power has capability of development of BOP and stack for large capacity, building, and vessel.

POSCO Power has been lined up the multi-scale power ranges from several hundred kW to tens of MW. Especially, we have commercialized the line-up of 350, 1400 and 2800 kW products and installed them as much as 22.5MW up to now in Korea. POSCO Power is a major power generation company in Korea and also had collaboration agreement with Fuel Cell Energy to transfer MCFC technologies including maintenance and manufacturing. Further, POSCO Power acquired the exclusive sales right of molten carbonate fuel cell in Korea, and it is paving its road to the global market.

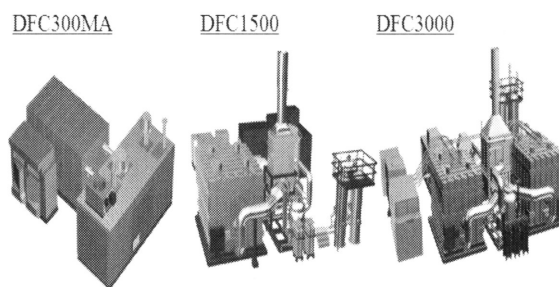

Fig.5. Line-up of MCFC products (FCE/POSCO Power)

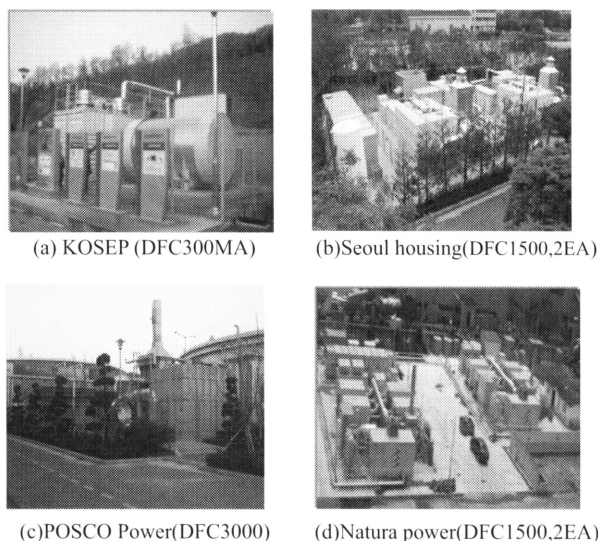

Fig.6. Primary installations by POSCO Power in Korea

DFC300 model produces 300kW power per hour. Installation area within 30~40 square meter space represents much smaller status than other same level generator. If it can install in various areas, it would be possible to take advantages in buildings such as small production facilities, hotels, universities, and even food / beverage manufacturing plants producing the anaerobic digester gas. And DFC1500 model is capable to produce 1400kW power per hour. This model can take advantages in a small sewage treatment plants, landfills, large hotels and hospitals, manufacturing facilities, etc. with its area, 100~150 square meters space. Furthermore, DFC3000 model, producing 2800kW power, can be installed at universities, manufacturing facilities which are relatively big area and high power consumption requirements.

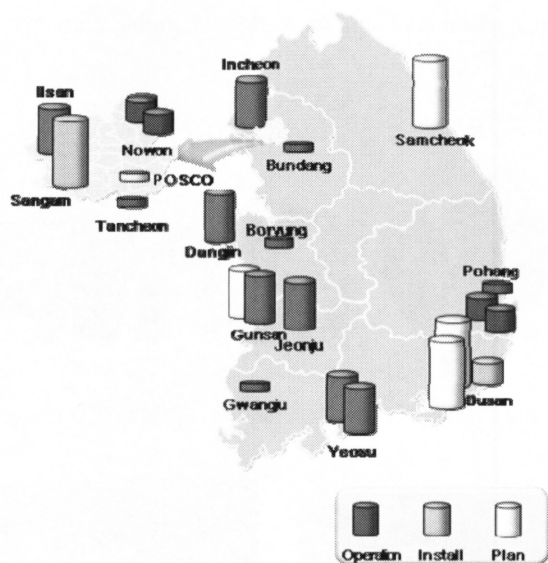

Fig.7. MCFC installation status by POSCO Power in Korea

MCFC installation status by POSCO Power in Korea is summarized in Fig. 7. From 22.9 MW operations during 2006 and 2009, huge potential became identified: utility, IPP, local government, construction companies. Remote monitoring & control center was established on April 2009 for the purpose of stable operation and control of fuel cell power plants nation-wide. CDM methodology was begun for fuel cell power plant at 2009. As a response for forthcoming RPS, localization became

expanded to the mass production, quality improvement. Manufacturing capacity will be expanded from 150MW/yr to 500MW/yr. The preparation for metropolitan city can be summarized:

- (i) Seoul city completed 2.4MW fuel cell power plant → expansion to other cities
- (ii) Future plan: Seoul new-town (20MW), Incheon songdo (30MW), Sejong city (40MW).

Since POSCO Power is completed to commercialize direct fuel cell System series as mentioned above with FCE, POSCO Power has installed the fuel cell power generating system of total 22.5MW up to now, e.g. KOSEP, Seoul housing in Seoul, and the Pohang Fuel Cell Power etc. including the Natura Power in the nation.

Recently, Seoul city has announced a vision of green energy as “Global Leader City for Green Growth” in order to achieve environmental friendly, green growth and high flexibility. Seoul would be the first city to select and focus on the fuel cell power plant for metropolitan clean & low carbon energy solution. A way of achieving of Seoul city’s vision was introduced as below:

- (i) Load following rate: 2% / min
- (ii) Enhance current regulatory frameworks: require fuel cell installation within new-town place quota to heavy energy consumer mandatory installation of fuel cell in public building.



Fig.8. Global market development

With strong success of fuel cell market in Korea, POSCO Power will be focusing on the global market, especially ASEAN [The Association of Southeast Asian Nations], China and Middle East. Because these countries are known as a “entrance” market for other international markets due to a lack of power supply, low fuel cost, and argumentation of electric power price.

R&D status of POSCO Power

With Seoul city’s vision, POSCO Power plans to install molten carbonate fuel cell on POSCO Center in Seoul and also schematic layout of 10MW class MCFC system.

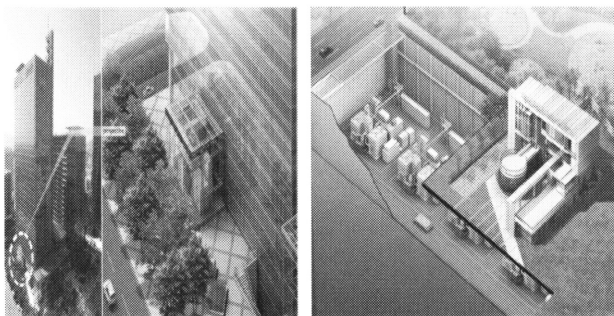

Fig.9. Schematic layout of MCFC installation on POSCO Center (L) and 10MW Class(R)

So far the success of fuel cell at POSCO Power was based on a stationary fuel cell application. POSCO Power will be applied to various areas to diversity for their fuel cell application in terms of diversity of fuel cell business market. In particular, based on existing stationary application, it is expected to enter the expanding field for new market penetration such as “uninterrupted power generator” for the fast load response at sudden electrical failure, “ship service fuel cell”, and “large-scaled fuel cell” required mass production and high efficiency by turbine combination.

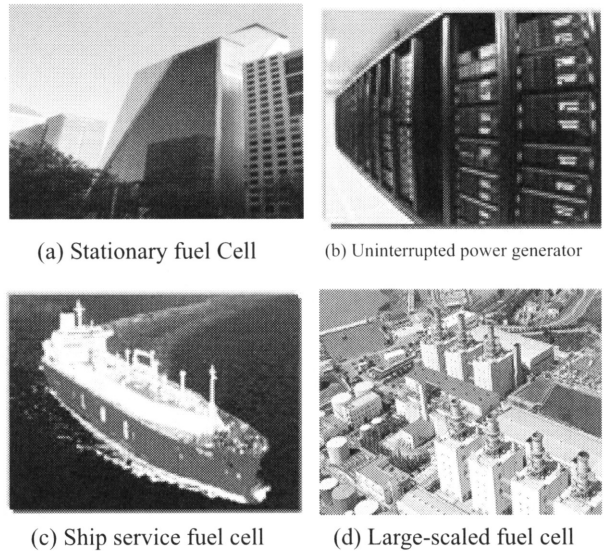

Fig.10. New market penetration of POSCO Power business

The main purpose of the development of fuel cell for a “uninterrupted power generator” are targeted due to

- (i) Increment of economic losses and damage due to power failures:
 - Domestic incidents; the past 10 years ('98 ~ '07) 136's average of domestic power failures.
 - Yeosu National Industrial Complex accident; 2008 May 2 turn downtime outages, damage 100 billion won
- (ii) Existing emergency power system’s problems:
 - Checking the status of practical difficulties
 - Not real-time monitoring of the equipment condition
 - Aging equipment

Based on these circumstances, even though novel concept of “UPS” and redundant power supply lines are introduced, these solutions are required enormous operation cost and time-consuming so that the terms of “uninterrupted power generation” are introduced to prevent of electricity failure. POSCO Power has proposed the target goals as below:

- (i) Load following rate: 2% / min

- (ii) Switching cycle: 0.5 cycle
- (iii) High-frequency distortion: 5%
- (iv) Output variability: 10%/min
- (v) Electrical efficiency: 47%

For the development of ship service fuel cell, POSCO Power is to develop ship auxiliary power unit first, then ship service fuel cell for main propulsion as a step-by-step approach. To achieve the optimization of fuel cell system for ship propulsion are needed to consider issues such as “feedstock”, “marine environment”, “low load-following capacity”, “durability”, and “space constraint”.

For guidance, POSCO Power proposes the following specification for optimization on maritime environment:

- (i) Anti-vibration: 4G
- (ii) Anti-inclination: 22.5°
- (iii) Anti-salinity: ~790 ppm

More information is necessary about the ship service fuel cell related technology of FCE and POSCO Power to proceed with the discussion with the Korean Government and launch the project. The information could be: the achievement of the ship service fuel cell project by FCE (demonstration hour, degradation rate, target and actual efficiency, target and actual output ratings, kinds of fuels used and its usage per hour, and so on), the reforming technology of logistic fuel, new technology implemented in the system (ex. water recovery)

Table 1. New market penetration of POSCO Power business

	Stationary fuel cell (stand-alone)	Uninterrupted power generator	Ship service fuel cell	Large-scaled fuel cell
Potential customer	Apartment, University, Government building	IDC, Industrial complex	Shipping company	Utility, IPP
Introducing factor	Emission reduction within metropolitan city territory	Countermeasure of electricity failure	'16 MARPOL observance (NOx, carbon tax, etc.)	RPS (renewable portfolio standard) District Heating
R&D field	Compact design, load management	Fast load following	Optimization on marine circumstance, fuel conversion, load following	Mass production, high efficiency by turbine combination

DFC/T fuel cell system in future

Molten carbonate fuel cell has been introduced to produce high power efficiencies among fuel cell system, POSCO Power is given an interests of MCFC hybrid system with gas turbine, Fig.11, which was already developed by FCE and also still being actively developing this system due to very high efficiency (>60%) and very low emissions (NOx : 0.004lb/MW-hr, CO : 0.075lb/MW-hr) compared with general DFC efficiencies (45~50%).

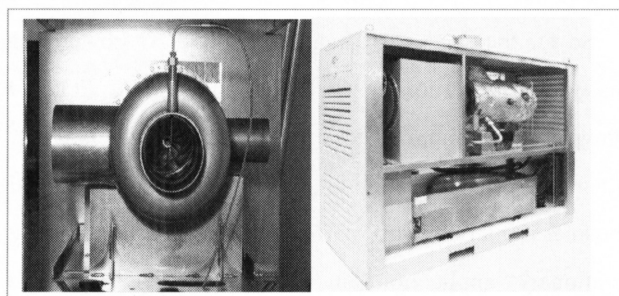

Fig.11. Front view of modified Capstone micro turbine

There are two main features of this hybrid method as atmospheric hybrid system and interactive hybrid system. Pressurized hybrid system is generally developed with pressurization of tubular SOFC by Siemens. Even though this structure has theoretically simple and high efficiencies to achieve in normal operation condition, it

showed the difficulties to operate heat-up, etc. However, DFC/T of FCE was chosen and applied the atmospheric hybrid system, then successfully operated with stability. And molten carbonate fuel cell is interacted with gas turbine as a part of system so that DFC and turbine are impossible to operate individually in existing system. These interactive parts such as heater, air eductor and oxidizer are needed to modify toward MBOP. Hence the power plant design consists of a novel waste heat recovery approach for extraction of heat from the fuel cell exhaust [1].

This hybrid system's principle concept shown in Fig. 12 [2] is basically to utilize the gas turbine for generation of additional power. Fuel cell is primary source of power generation and gas turbine is an auxiliary power generation. Air blower makes it feasible to run the power plant in two modes: 1) Fuel cell/turbine integrated mode, 2) Fuel cell only mode [3, 4] and also 3 skids such as HRU, HTR and LTR are introduced in this hybrid system. HRU is Heat Recovery Unit arranged to maximize the heat recovery from the cathode exhaust gas. HTR, i.e. high temperature recuperates is located between oxidizer and cathode of fuel cell and preheating the air in LTR.

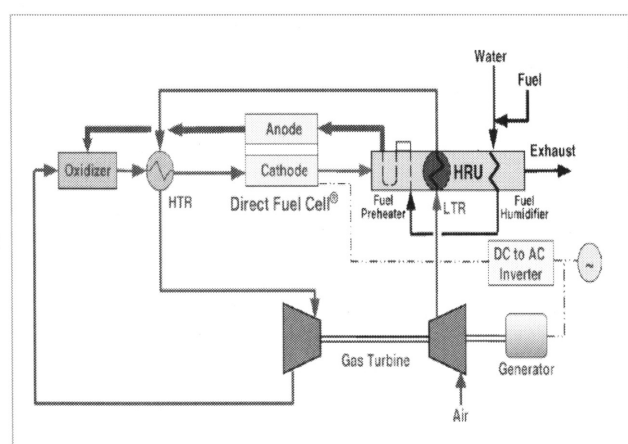

Fig.12. MCFC turbine hybrid system P&ID concept

Design modifications to the existing DFC-300A fuel cell module for its application to the DFC 300/T has been completed by FCE shown in Fig. 13

- (i) Power 322kW: 56%(LHV)
- (ii) Operating times: 8,000hrs (op. rate: ~90%)

Furthermore, FCE was completed to verify turbine hybrid system of MW-scale, 3.3 MW, and showed the result, more than 70% of power efficiency.

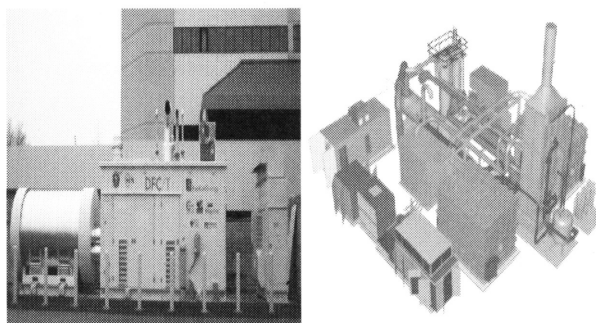

Fig.13. Demonstration of DFC/T 320kW (L) and 3.3MW (R)

Conclusions

Today increasing attention has been given to a molten carbonate fuel cell among renewable energy sources due to high efficiency of power and eco-friendly system. POSCO Power has been lined up the multi-scale power ranges from several hundred kW to tens of MW. Especially, molten carbonate fuel cell system by FCE and POSCO Power are commercialized to produce the line-up 350kW, 1.4MW and 2.8MW power scale.

POSCO Power has installed the fuel cell power generating system of total 22.5 MW up to now in Korea.

Under the success of commercializing of molten carbonate fuel cell of POSCO Power in Korea, POSCO Power will be applied to various areas to diversity for their fuel cell application in terms of diversity of fuel cell business market such as “uninterrupted power generator”, “ship service fuel cell”, and “large-scaled fuel cell” from domestic to global market.

References

1. H. Ghezal-Ayagh, A.J. Leo, R. Sanderson, High-Efficiency Fuel Cell System, U.S. Patent No. 6,365,290 (April 2002).

2. H. Ghezal-Ayagh, J. Walzak, D. Patel, J. Daly, H. Maru, R. Sanderson and W. Livingood, State of direct fuel cell/turbine systems development, *J. Power Sources* **152**, 219–225 (2005).
3. H. Ghezal-Ayagh and H. Maru, Direct fuel cell/turbine system for ultra high efficiency power generation, 2002 Fuel Cell Seminar Palm Springs, CA November 18–21 (2002).
4. H. Ghezal-Ayagh, J.M. Daly and Z. Wang, Advances in direct fuel cell/gas turbine power plants, Proceedings of ASME/IGTI Turbo Expo (2003) (ASME Paper GT 2003-38941).
5. J. Doyon, M. Farooque and H. Maru, The direct fuel cell stack engineering, *J. Power Sources* **118**, May 8–13 (2003).
6. M. Farooque and H. Ghezal-Ayagh, Molten carbonate fuel cells and systems, system design, part 7. in: W. Vielstich, A. Lamm and H. Gasteiger, Editors, *Handbook of Fuel Cells, Fundamentals Technology and Applications*, vol. 4. Fuel Cell Technology and Applications, Part 2, John Wiley and Sons, LTD., 942–968 (2003).